

☆ Sparkles of Joy

ACTIVITY BOOK

Created by
Aditi Wardhan Singh



Celebrate Diwali, Hanukkah, Christmas and World Cultures with **70+ activities**. Fun Puzzles, Word Searches, Creative Prompts, Coloring, Craft, Writing Exercises and MORE !!!

☆ Sparkles of Joy
ACTIVITY BOOK

Created by
Aditi Wardhan Singh



Celebrating Identity, Diversity and Inclusion with
Critical Thinking and Creative Prompts

Read the companion children's book **Sparkles of Joy**

Caleb, a new neighbor, joins a Diwali themed play date. Will Riya and her friends be able to make Caleb feel comfortable?

The Sparkling Me Series children's books are ideal for preschoolers, elementary aged kids, counselors and teachers looking to create cultural awareness along with social emotional learning.



Growth Mindset for Global Citizens

Empowerment Series Created by © 2021 Aditi Wardhan Singh

All Rights Reserved

No part of this publication may be reproduced, stored in a retrieval system or transmitted in any form by any means without permission from the author except for quotations in a book review. Bulk copies of this book and permission to reproduce may be requested by the email address
-contact@raisingworldchildren.com

Paperback ISBN – 978-1-956870-99-2

How I dress

Where I live

What I eat

My language

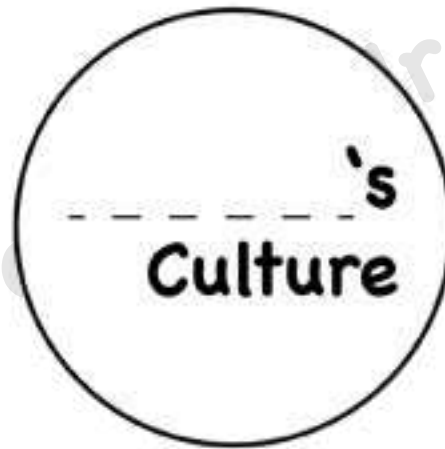

What I play

My family

Celebrations

Meaning of Name

I am special because....

Draw a picture of yourself

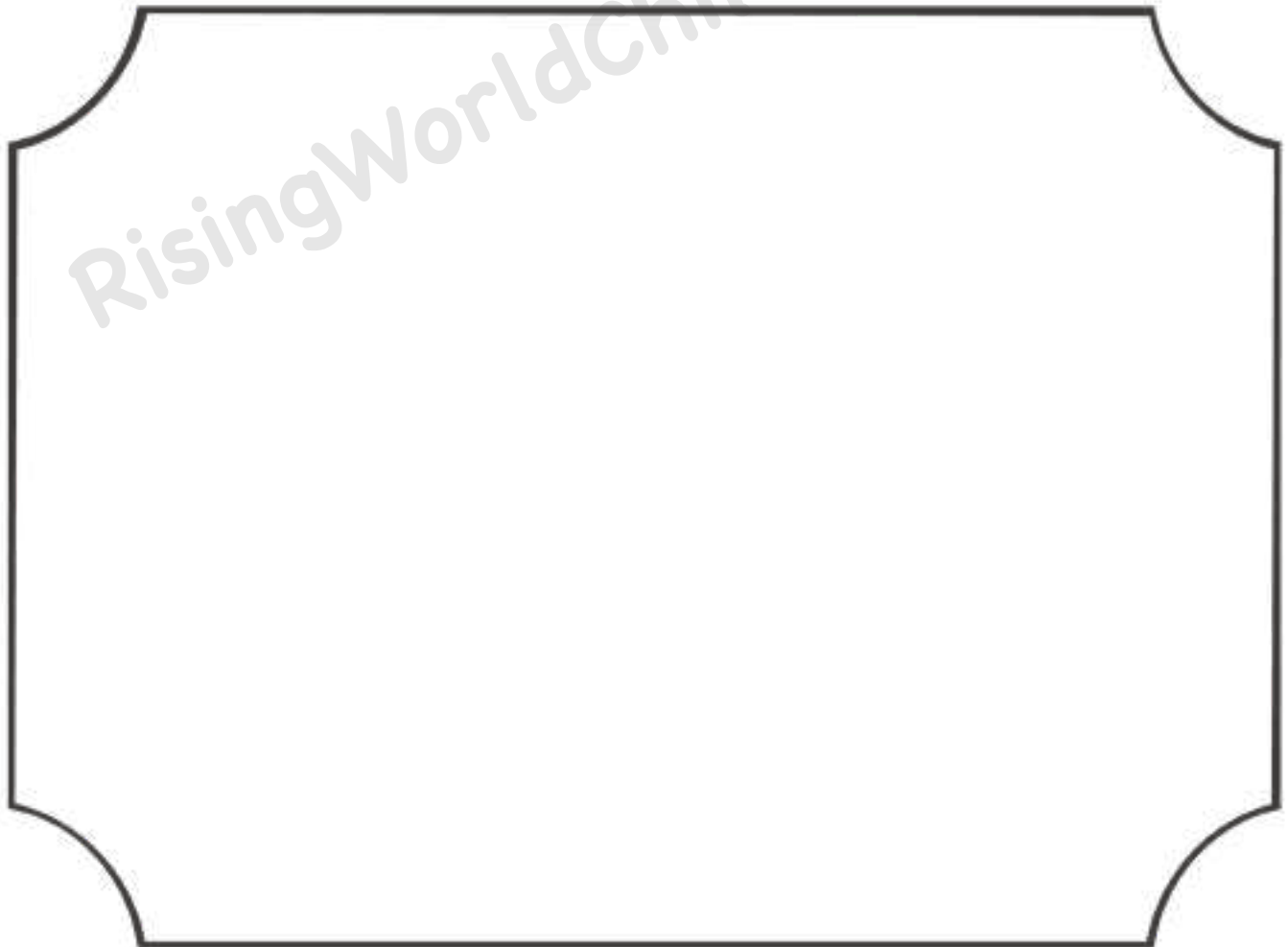



DIWALI

RisingSunAndChildren.com

Hindu - Diwali Diya Lamp

Lord Rama's wife _____ was captured by Ravana, the demon king with ten arms and _____ heads. After a great _____ in which Rama killed _____ they returned home and Lord Rama was crowned king. His people lit _____ outside their houses to guide and welcome Lord Rama and Sita home and drew _____ patterns to celebrate.

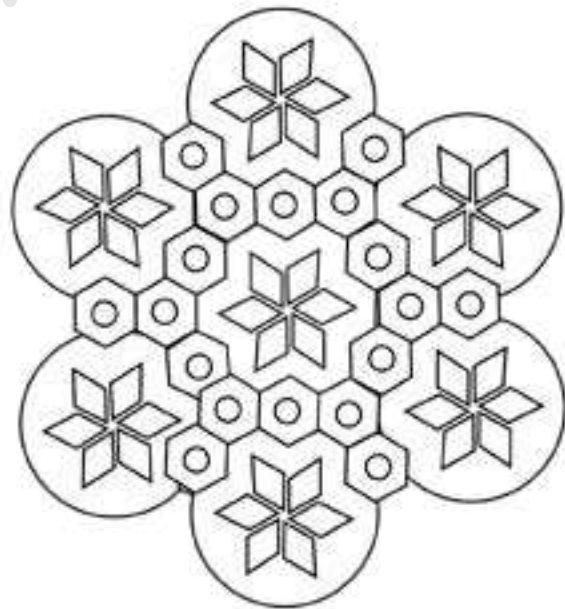

oil lamps Sita Ravana battle Rangoli ten



Diwali Maze

Help Hanuman find his way through the maze to Ravana so he can rescue Sita.

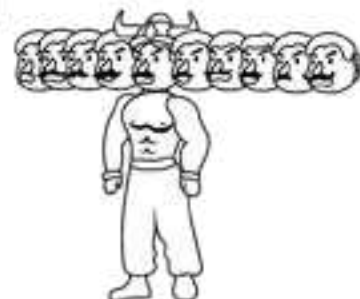
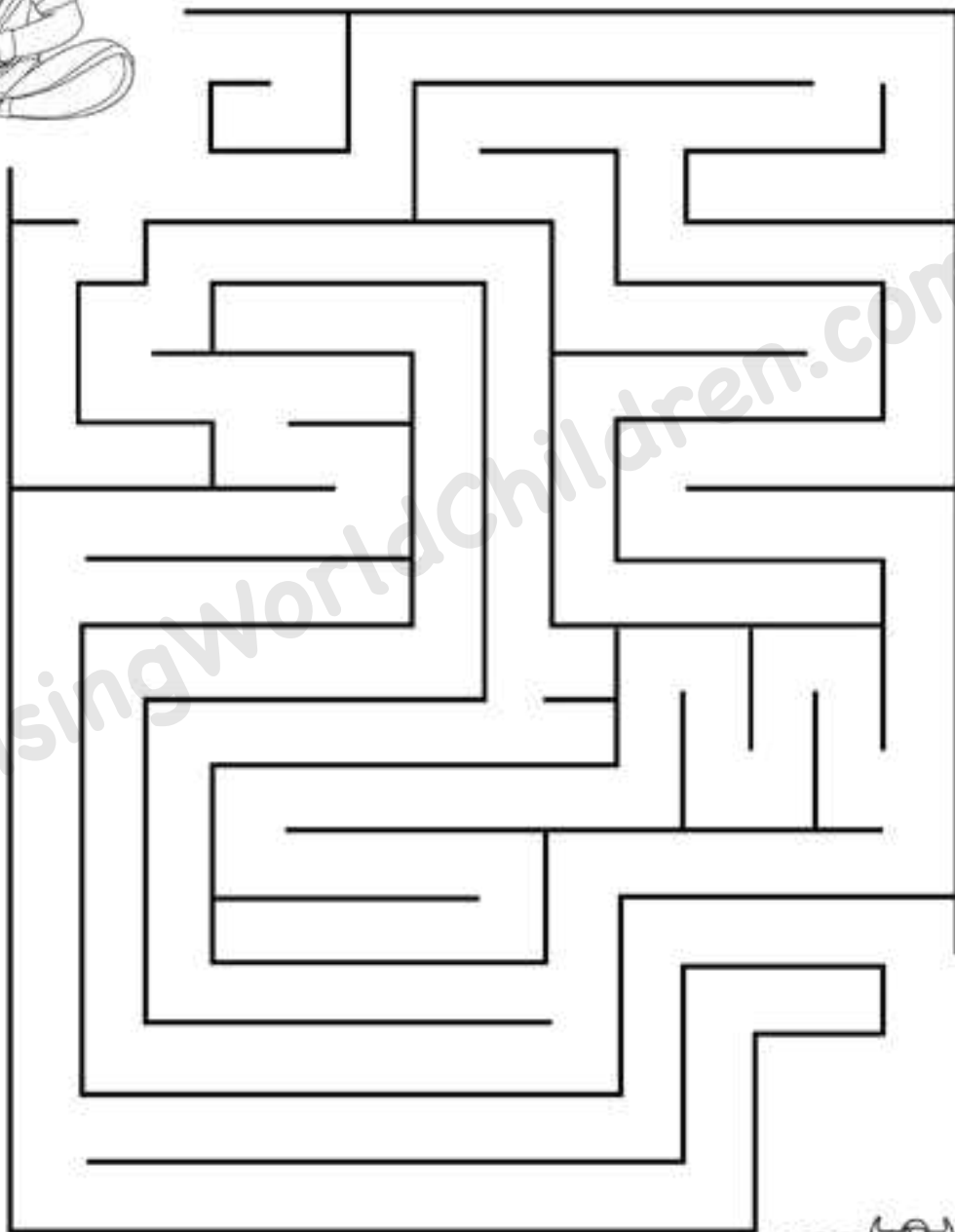

Diwali Word Scramble

Unscramble the Diwali themed words. First one is done for you

shimindu

hinduism

diani

maar

miskhal

skorwifer

higtls

asti

aidy

navaar

munahan





HANUKKAH

Risingwonderchildren.com

Make a Menorah for Hanukkah!

Cut , Paste & Colour

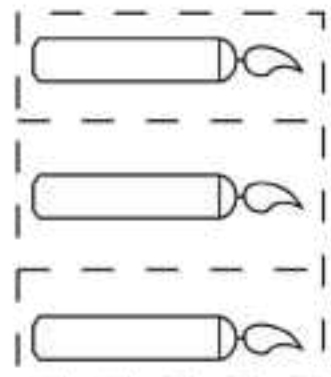
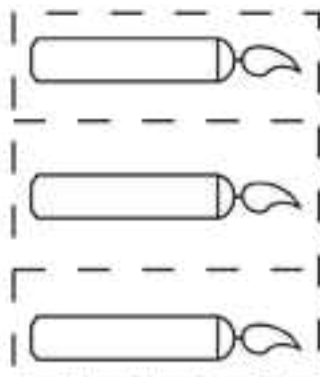
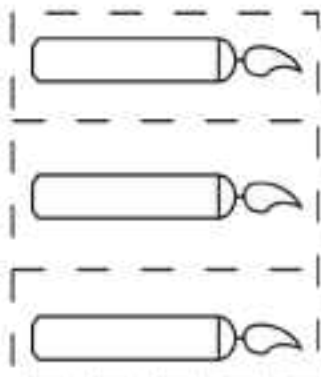
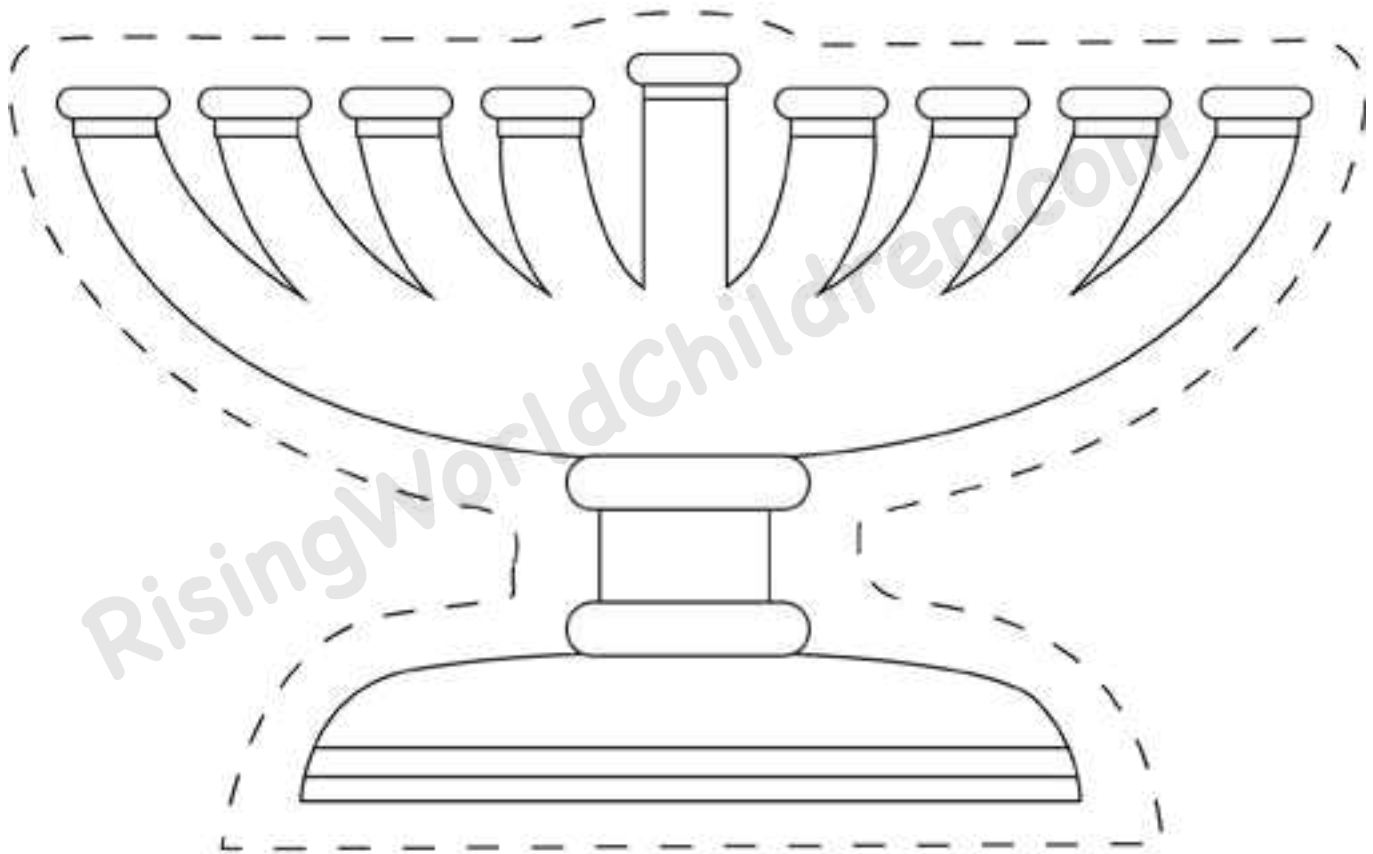

Find Each Term or Phrase in the Puzzle



Chanukah

Dreidel

Eight days

Festival of light

Hanukkah

Judaism

Maccabees

Matisyahu

Menorah

Nightfall

Iatke



Spelling List - Hanukkah



Learn these spellings below.

1) Hanukkah

4) Candles

7) Festival

10) Jewish

2) Menorah

5) Celebration

8) Rabbi

11) Hebrew

3) Synagogue

6) Dreidel

9) Sabbath

12) Lights

Spelling Work

Now put the spellings in alphabetical order below

1) _____

4) _____

7) _____

10) _____

2) _____

5) _____

8) _____

11) _____

3) _____

6) _____

9) _____

12) _____

Choose the correct word from the spelling list to complete these sentences.

a Hanukkah is also known as the Festival of _____

b _____ is a four-sided spinning top

c _____ is a teacher of Torah.

d _____ is a nine-branched candelabrum.

e _____ is a Jewish house of prayer.

f Some Jewish people view the _____ as the day of worship.



RisingUpChildren.com

CHRISTMAS

Match Words and Pictures

Angel	<input type="checkbox"/>
Candy Cane	<input type="checkbox"/>
Ornaments	<input type="checkbox"/>
Christmas bells	<input type="checkbox"/>
X-mas candle & holly	<input type="checkbox"/>
Christmas card	<input type="checkbox"/>
Christmas lights	<input type="checkbox"/>
Christmas pudding	<input type="checkbox"/>
Christmas tree	<input type="checkbox"/>
Gingerbread man	<input type="checkbox"/>
Present	<input type="checkbox"/>
Reindeer	<input type="checkbox"/>
Santa Claus	<input type="checkbox"/>
Santa's hat	<input type="checkbox"/>
Santa's sleigh	<input type="checkbox"/>
Snowflakes	<input type="checkbox"/>
Snowman	<input type="checkbox"/>
Stocking	<input type="checkbox"/>



Christmas Tree Color By Number

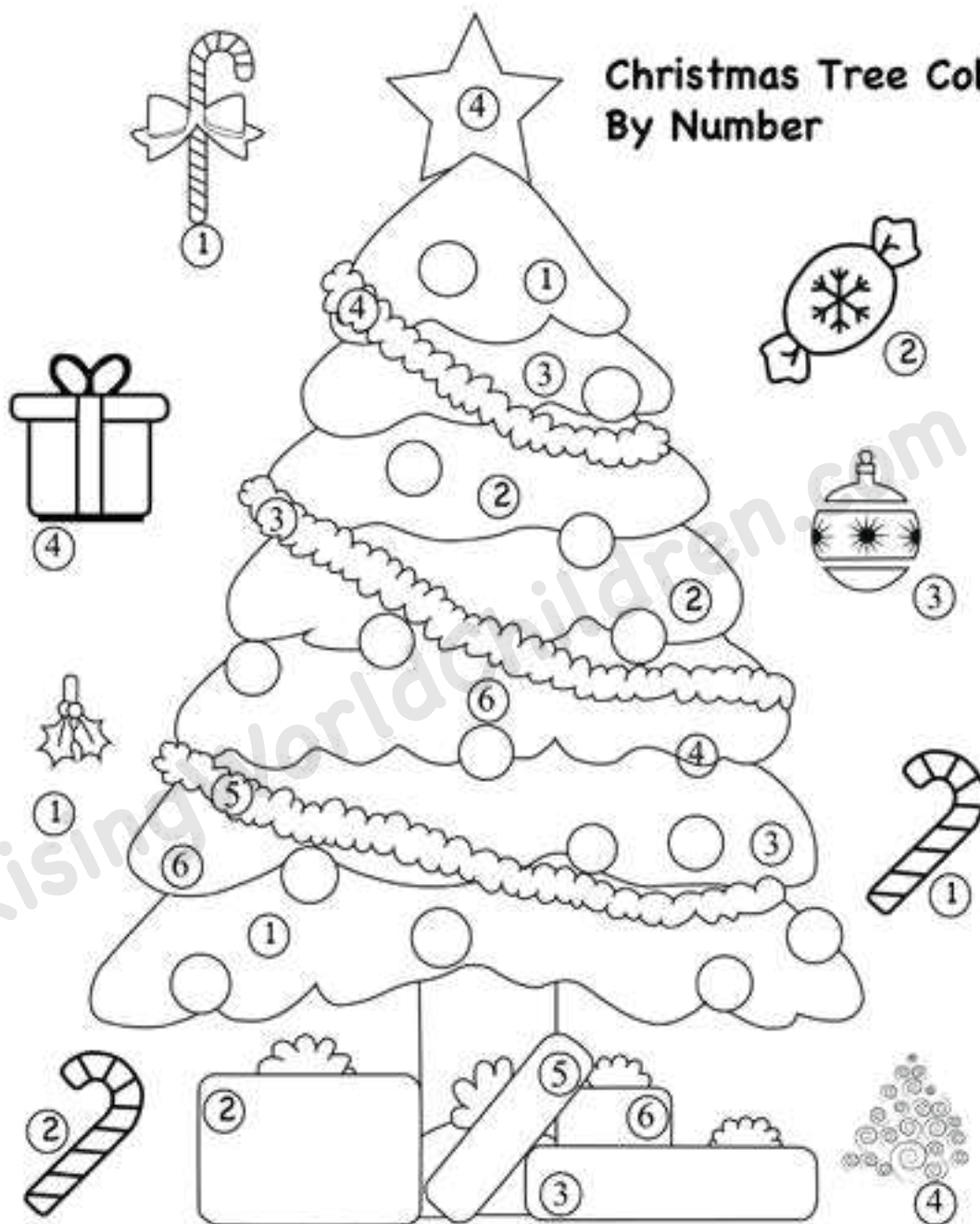

- | | | | | | | | | | | | |
|---|--|-------|---|--|-------|---|--|--------|---|--|------|
| 1 | | Red | 2 | | Green | 3 | | Yellow | 4 | | Pink |
| 5 | | Brown | 6 | | Blue | | | | | | |

Can You Help the Monkeys
Reach the Christmas Tree?





WORLD CULTURES

RisingWorldChildren.com

What are different ways you can greet friends around the world?
Match the following

Germany

Bow or shake hands

Japan

Press your hands together and slightly bow

Argentina

Handshake, fist bump, hug, or wave

France

Place your palms together and say "Namaste"

Thailand

Kiss on the cheeks three or four times

United States

A firm handshake

India

A hug and kiss on the cheek

China

Bow

China: Bow or shake hands / Germany: A firm handshake/ India: Place your palms together and say "Namaste"/
Japan: Bow/ Argentina: A hug and kiss on the cheek/ United States: Handshake, fist bump, hug, or wave/
France: Kiss on the cheeks three or four times/ Thailand: Press your hands together and slightly bow

My Favorite Festival

1). What is your favorite festival?

2). When is it celebrated?

3). Why do we celebrate it?

4). How do you celebrate it?

5). Which special food is prepared on that day?

6). What do you wear on that day?

Festivals and Traditions

(Match with the months)

- ★ February
- ★ 25 December
- ★ 11 November
- ★ 31 December
- ★ 1 January
- ★ 5 November
- ★ 1 April
- ★ 31 October
- ★ three Sundays before Easter
- ★ third Sunday in June
- ★ in March or april
- ★ Father's Day
- ★ New Year's Day
- ★ Bonfire Night or Guy
- ★ Christmas
- ★ Easter
- ★ Hogmanay
- ★ April Fool's Day
- ★ Mother's Day
- ★ Remembrance Day
- ★ Halloween
- ★ Valentine's Day

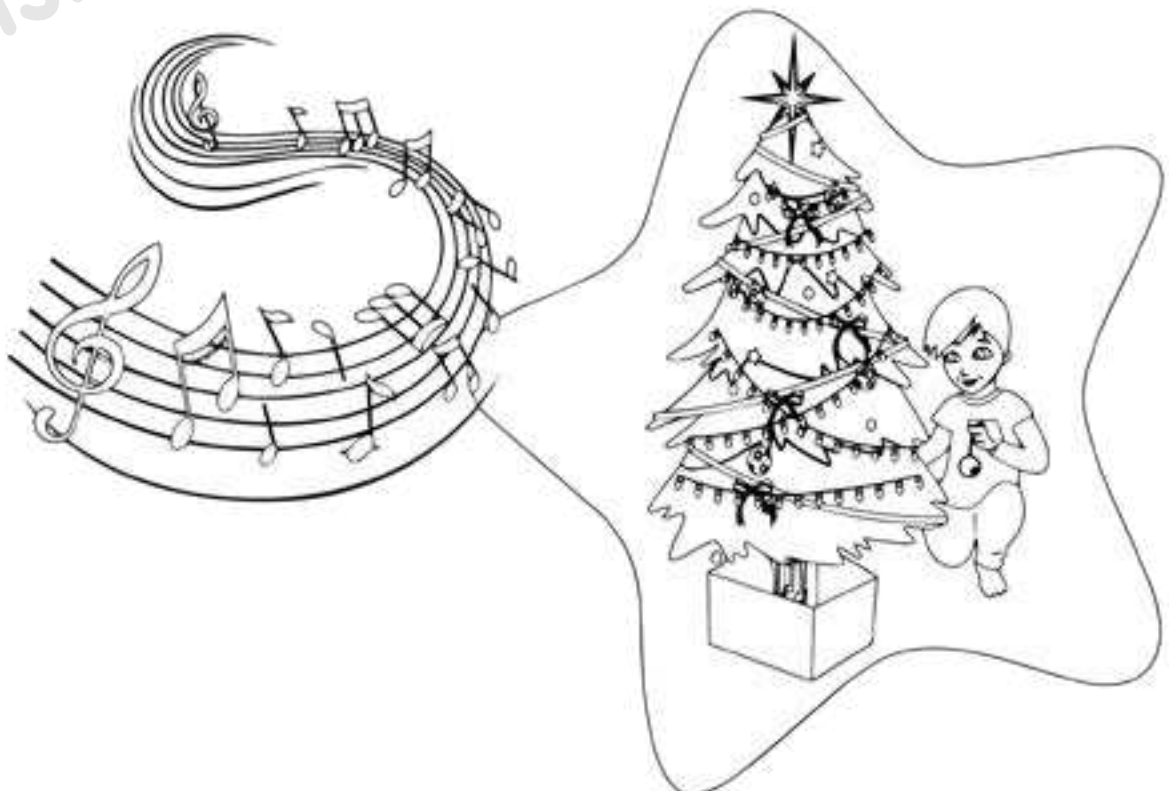

Cultural Appreciation Journaling Prompt Ideas

✦ Why are cultural celebrations such an important part of society?

✦ What cultural celebrations does your family participate in?

✦ Which cultural celebration is your favorite? What do you like about it?

✦ How did you become a part of the different cultures you are involved in? Were you born into them, or did you choose to belong to them? Which culture is most important to you?

✦ Do cultures define who we are as people—or do our shared experiences define culture? Why?

✦ How do the clothes we wear and the way we present ourselves reflect our cultures?

RisingWorldChildren.com

Namaste. This book is inspired by the children's book Sparkles of Joy (picture below). The Sparkling Me children's books are inspired from the second book Sparkles of Joy. If you enjoyed these activities, do leave a few encouraging words as a review on Amazon/GoodReads or our website - RaisingWorldChildren.com

Tag @raisingworldchildren on Instagram

Keep sparkling!



Aditi Wardhan Singh is multi award-winning, best-selling. Featured on several global publications and broadcasts, she is one of the leading voices on cultural sensitivity and self-empowerment.

In 2017, she founded RaisingWorldChildren.com, a global online and in print publication for multicultural families.



Aditi is an Indian American, raised in Kuwait. Her books aim to give children a strong sense of identity while building cultural awareness, with a sprinkle of faith and science. Excellent resources for counselors, parents, and teachers for creating positive and impactful conversations. To learn more about Aditi's books and the work she does in lifting the voices of diverse authors, visit RaisingWorldChildren.com

Sparkles of Joy: <https://amzn.to/3aIDINU>

Activity book: <https://amzn.to/3n4wWIp>

